

# Parker Programmable Timer/Controller FPM-PTC



## Installation, Operating & Maintenance Manual



ENGINEERING YOUR SUCCESS.

## WARNING - USER RESPONSIBILITY



**FAILURE OR IMPROPER SELECTION OR IMPROPER USE OF THE PRODUCTS DESCRIBED HEREIN OR RELATED ITEMS CAN CAUSE DEATH, PERSONAL INJURY AND PROPERTY DAMAGE.**

This document and other information from Parker Hannifin Corporation, its subsidiaries and authorized distributors provide product or system options for further investigation by users having technical expertise.

The user, through its own analysis and testing, is solely responsible for making the final selection of the system and components and assuring that all performance, endurance, maintenance, safety and warning requirements of the application are met. The user must analyze all aspects of the application, follow applicable industry standards, and follow the information concerning the product in the current product catalog and in any other materials provided from Parker or its subsidiaries or authorized distributors.

To the extent that Parker or its subsidiaries or authorized distributors provide component or system options based upon data or specifications provided by the user, the user is responsible for determining that such data and specifications are suitable and sufficient for all applications and reasonably foreseeable uses of the components or systems.

## DESCRIPTION

The FPM-PTC is a versatile, easy to operate, programmable timer/controller for use with the Parker Fuel Polishing Module or other 12 VDC powered devices aboard your vessel.

Combining 24 hour/7 day switching, and capable of up to 8 on/off cycles per day (56 cycles per week), the FPM-PTC allows for flexible and reliable unattended operation of your Parker Fuel Polishing Module.

The FPM-PTC is equipped with an internal lithium backup battery that will last for up to 5 years before replacement is necessary.

## QUICK REFERENCE

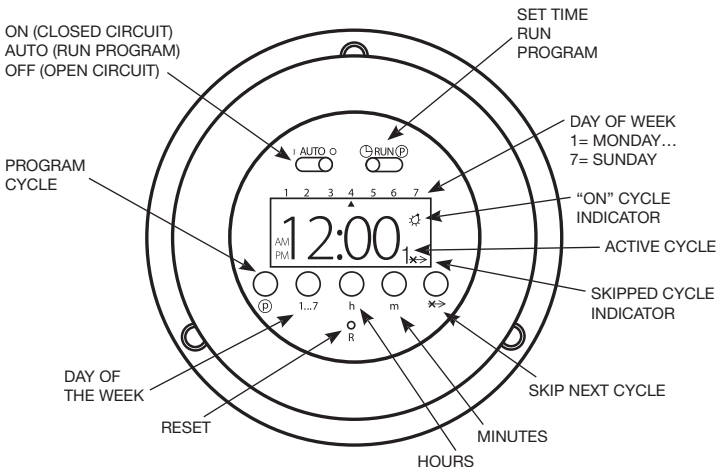

Figure 1: Timer/Controller Functions

## INSTALLATION

Before beginning your installation, read this entire manual to familiarize yourself with the proper installation and operation of your FPM-PTC.

Prior to installation, gather all tools and materials necessary.

We recommend:

- #4 screws (3X) of sufficient length and screwdriver for mounting
- Drill with bits for drilling pilot holes and to run wiring
- Approved electrical connectors (4X) and crimping tool, if required, for wiring
- Boat cable (Type UL 1426 16AWG minimum) as needed
- Electrician's fish tape for pulling wires or cables through bulkheads or raceways
- Split wire loom and cable ties to secure wiring
- 3.25 inch hole saw (for recess mount option only)

Begin by laying out the installation as intended before drilling or cutting any materials. This will help to identify any other items that you may need pertaining to your installation.

Choose a location that will provide easy access to the FPM-PTC. The housing and bezel are designed to protect the timer/controller from light rain and sea spray, however, the unit must be located away from areas that are prone to excessive moisture or flooding.

Keep in mind, when you choose a location for your FPM-PTC, it will be necessary to supply power (12 VDC) *to* your timer/controller and *from* the timer/controller to the device that will be controlled (i.e., fuel polishing module).

It is often convenient to connect the FPM-PTC to an existing 12 V circuit such as a 12 V appliance outlet. In order for the timer/controller to operate while the vessel is unattended, the circuit to which the FPM-PTC is connected must also remain on.

## Mounting

The FPM-PTC can be either surface or recess mounted as a matter of preference.

To mount your FPM-PTC to a suitable surface, begin by removing the outer bezel from the housing by grasping the edges and pulling firmly. A slight twist of the bezel will ease removal, if necessary. This will provide clear access to the three mounting holes. Place the timer housing in the desired location and orientation and mark each hole location. Refer to Figure 2. The three mounting holes are designed to accept #4 screws. Brass or stainless steel fasteners are recommended for resistance against corrosion. Drill pilot holes in each of the three locations previously marked.

If you prefer recess mounting, ensure that adequate access is available behind the panel to which the FPM-PTC will be affixed. A 3.25 inch (83mm) hole saw may be used to make the panel cutout for the housing. The maximum allowable panel thickness for recess mounting is 3/8 inch (9.5mm).

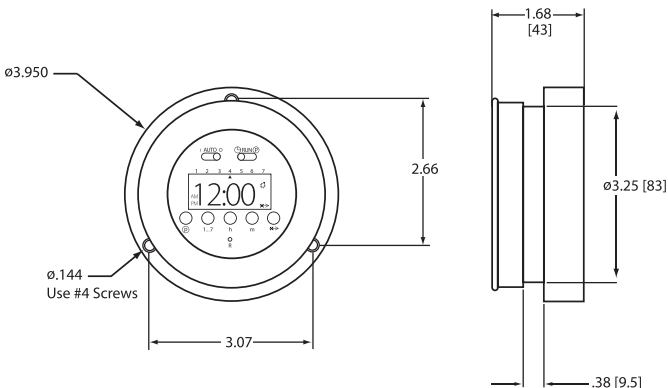

Figure 2: Installation Dimensions

## ! CAUTION

1. NEVER WORK ON THE ELECTRICAL SYSTEM WHILE IT IS ENERGIZED.
2. DO NOT INSTALL ELECTRICAL COMPONENTS THAT EXCEED THE RATED CURRENT (AMPERAGE) OF THE CIRCUIT.

### Wiring

The FPM-PTC is provided with four wires for powering your device:

**Red** – Positive 12 VDC supply (from DC panel)

**Black** – Negative 12 VDC supply (DC system ground)

**Black** – Negative 12 VDC supply (to device ground)

**Orange** – Switched positive 12 VDC supply (to positive lead of device)

*Note: The black (negative) leads are common.*

The FPM-PTC must be connected to the 12 VDC power supply with the correct polarity. The red wire must be connected to the positive 12 VDC source and the black wire must be connected to the DC return (negative). Reversing polarity of the electrical connections will void all warranties and potentially render the FPM-PTC inoperable.

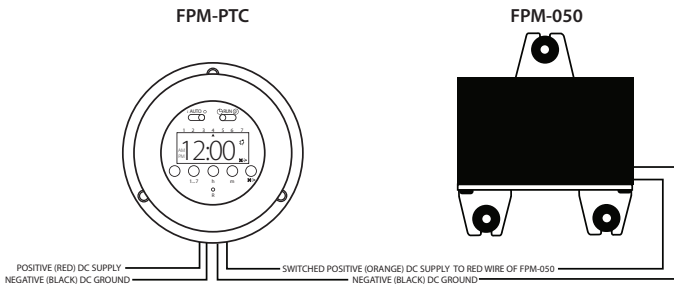

Figure 3: Wiring Diagram with Parker Fuel Polishing Module

Connect your FPM-PTC to the electrical circuit using standard electrical practices in accordance with all local, state, and federal laws. Connect one of the black leads to the negative side of the DC circuit. Ensure that the DC circuit is properly grounded in accordance with standard practices. Connections should be made between the FPM-PTC, DC supply power, and any other electrical devices using connectors approved for use by relevant industry and governmental bodies. Wire nuts should never be used to make electrical connections aboard a boat.

It is recommended that unsheathed electrical conductors be covered with split wire loom and held in position using cable ties to secure the lines to panels or bulkheads. The wire loom will help protect the leads from wear and exposure to corrosive fluids. Connect the red lead of the FPM-PTC to the positive side of the DC circuit. The remaining black lead is to be connected to the negative wire of your device. Finally, connect the orange lead to the positive side of your device. Check all of your connections before final installation of the FPM-PTC.

Attach the FPM-PTC to the panel or bulkhead using the appropriate fasteners as described earlier in this section. Restore power to the DC circuit as required.

# OPERATING INSTRUCTIONS

## Programming

Programming your FPM-PTC is designed to be simple and fast by means of push buttons and display prompts.

### i. Setting the current time and day

Slide the **RUN** switch to the clock position (left).

Use the **1...7** button to select the correct day (1 = Monday...7 = Sunday).

The pointer ▲ advances one day each time the button is pressed.

Use the "**h**" and "**m**" buttons to set the current time. *Note that the AM/PM indicator on the LCD display changes each time the hour value passes 12.*

### ii. Setting an ON/OFF cycle

Slide the **RUN** switch to the program **P** position (right).

Use the **1...7** button to select the day of the week on which the program cycle will run. *Note that the pointer ▲ now advances through each day of the week and also through groups of days, namely, Monday – Friday (1 – 5); Saturday – Sunday (6 – 7); Monday – Saturday (1 – 6); and Monday - Sunday (1 – 7). This can save time when programming cycles that you intend to repeat on multiple days.*

After you choose the day or group of days desired, use the program **P** button to select the **ON/OFF cycle number** that you wish to program.

**Note:** Odd numbers indicate "ON" cycles, as indicated by the light bulb icon on the LCD display, and even numbers are "OFF" cycles.

The FPM-PTC allows you to program up to eight unique **ON/OFF** cycles for any given day. Use the "**h**" and "**m**" buttons to set the time at which your FPM-PTC will turn on (odd cycle) and off (even cycle) your device. Repeat this as desired to set additional **ON/OFF** cycles. If an **EEE** appears on the display at any time, a setting error exists and should be corrected to ensure that each program cycle runs as intended. If you want to clear a

program cycle, simply select the day and cycle number you wish to clear, and simultaneously press the **P** and **X→** buttons until the display reads 0:00.

To clear all previously stored program information, press the reset **R** button. Activate your program by sliding the **AUTO** switch to the auto position (middle) and the **RUN** switch to run (middle).

### iii. Skipping a cycle

Use the skip button **X→** to skip the next day's program cycle if you choose. *Note that the skipped cycle icon appears on the display.*

### iv. Manual override

You may, at any time, override your program schedule by sliding the **AUTO** switch to **I** (always on) or **O** (always off), much like any simple **ON/OFF** switch.

## MAINTENANCE

### Cleaning

To clean your FPM-PTC, polish outside surfaces with a soft cloth. The lens is made from high impact plexiglass. A mild liquid detergent may be used with water to clean the inside and outside surfaces of the lens if required.

**Never use ammonia-based or abrasive products to clean any portion of your FPM-PTC.**

### Basic Maintenance

The FPM-PTC is designed to be maintenance free. However, the internal backup battery may, on occasion, require replacement. Note that the battery is only used (to maintain stored program information) when the FPM-PTC is not connected to an external power source, such as a boat's DC system. The FPM-PTC will continue to operate and retain program information with a depleted internal battery as long as power from an external source is supplied to the unit.

---

If you choose to replace the battery, you will need to gain access to the internal battery compartment. To do this, remove your FPM-PTC from its mounting location. Ensure that the power supplied to the unit is **TURNED OFF** (de-energized). Turn the unit over and carefully remove the back plastic cover plate by prying it off with a small flathead screwdriver or similar device. Remove the internal timer/controller module from the outer housing by grasping firmly and pulling. Note the four small recessed clips on each side of the module.

Using the same small screwdriver or similar device, gently push each of the four clips until they release. The back should then separate from the front panel exposing the internal battery. Carefully remove the battery by sliding it from its metal retaining clip. Note that the positive (+) side of the battery faces toward you. *Refer to the Technical Specifications section of this manual for the correct battery replacement type.*

Place the new battery into the metal clip, ensuring that the positive side is visible and the battery is fully retained. Replace the back cover, making sure that none of the wires are pinched as you do so. Also, make sure that the back cover is in the correct orientation, with the external electrical connections facing down with respect to the front panel. Replace the timer/controller module in its housing.

Rotate the module within the outer housing if necessary to achieve the correct orientation. Replace the back plastic cover plate by snapping firmly into place, again making sure that the wire relief and mounting holes are properly aligned. Replace your FPM-PTC to its original location and restore power to the unit as necessary.

## TECHNICAL SPECIFICATIONS

- |                                       |   |
|---------------------------------------|---|
| <b>a. Operating Voltages</b>          | 12 VDC  |
| <b>b. Rated Power</b>                 | 3.5 VA  |
| <b>c. Switching</b>                   | SPST  |
| <b>d. Switch Rating</b>               | 16 A @ 45°C (113°F)<br>10 A @ 55°C (131°F)  |
| <b>e. Operating Temperature Range</b> | -10°C (14°F) to 55°C (131°F)  |
| <b>f. Approvals</b>                   | UL<br>CSA Pending   |
| <b>g. Back-up Battery</b>             | Li-Mn 3V<br>Type CR 2032  |
| <b>h. Setting Options</b>             | Time of day, Single day, Repeat program for recurring cycles,<br>1-2-3-4-5 (Monday through Friday), 1-2-3-4-5-6 (Monday through<br>Saturday), 1-2-3-4-5-6-7 (Monday through Sunday), 6-7 (Saturday<br>and Sunday), Skip-a-day function, Manual override |

## FOR TECHNICAL SUPPORT

**Parker Energy Systems**  
95 Edgewood Avenue  
New Britain, CT 06051 USA

Tel: +1-877-217-4501  
Fax: +1-877-781-7426

[www.parkerfuelpolishing.com](http://www.parkerfuelpolishing.com)  
[info@parkerfuelpolishing.com](mailto:info@parkerfuelpolishing.com)

Parker Programmable Timer/Controller  
Installation and Operating Manual  
FPM-PTC IOM, C02752-000 Rev. A, 03/2009



©2009 Parker Hannifin Corporation  
Patent Pending